



CSA/ASC B651:23

National Standard of
Canada



Accessible design for the built environment



Accessibility Standards
Canada

Normes d'accessibilité
Canada



National Standard of Canada

CSA/ASC B651:23

Accessible design for the built environment



*®A trademark of the Canadian Standards Association,
operating as "CSA Group"*



Published in January 2023 by CSA Group
A not-for-profit private sector organization
178 Rexdale Boulevard, Toronto, Ontario, Canada M9W 1R3
1-800-463-6727 • 416-747-4044

To purchase standards and related publications, visit our Online Store at www.csagroup.org/store/ or call toll-free 1-800-463-6727 or 416-747-4044.

ICS 91.140.01
ISBN 978-1-4883-4659-0

© 2023 Canadian Standards Association
All rights reserved. No part of this publication may be reproduced in any form whatsoever without the prior permission of the publisher.

Figure 56 b)
Seating at tables and counters — Counters
(See Clause [6.7.1.1.](#))

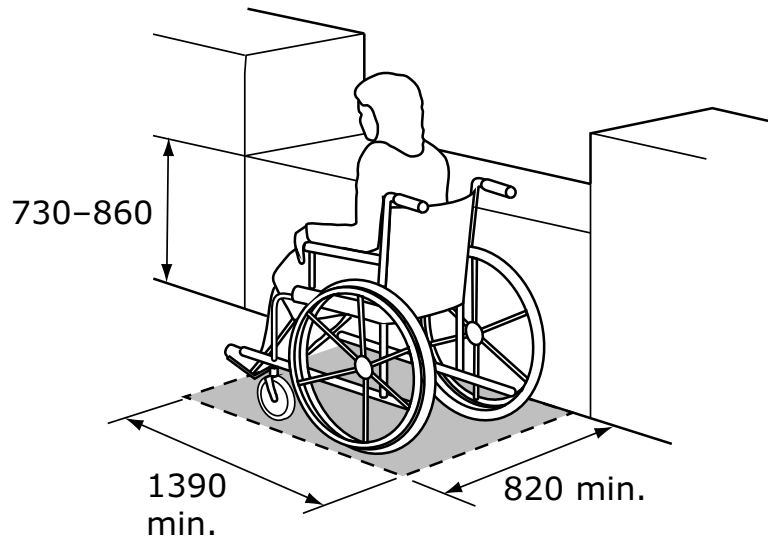

This figure shows a person in a wheeled mobility device seated alongside a counter that is 730 to 860 mm above the floor. The clearance area in front of the counter is 820 by 1390 mm.

Note: All dimensions are in mm.

6.7.2 Rest area seating

6.7.2.1 Bench or seat area

A bench or seat area shall

- a) be located adjacent to an accessible route;
- b) have a level and firm surface; and
- c) have an adjacent area that is level and firm, at least 850 by 1390 mm, and not part of the route of travel.

Notes:

- 1) Benches or seats should be set back from the accessible route.

- 2) The level area adjacent to the seat can accommodate a person using a wheeled mobility device, a service animal, stroller, walker, etc. (see Figure [57](#)).
- 3) The ground or floor surface of the seating area should contrast in colour and texture with the surrounding surface.
- 4) Consider providing a bench or seat every 30 m within the rest area.

6.7.2.2 Benches or seats

A bench or a seat shall

- a) be stable;
- b) have a seat height between 430 and 485 mm from the floor; and
- c) where there is more than one, provide a mix of options, i.e., some with backrests, some with armrests, and some with both.

Figure 57
Bench area
(See Clauses 6.7.2.1 and 8.6.3.1.)

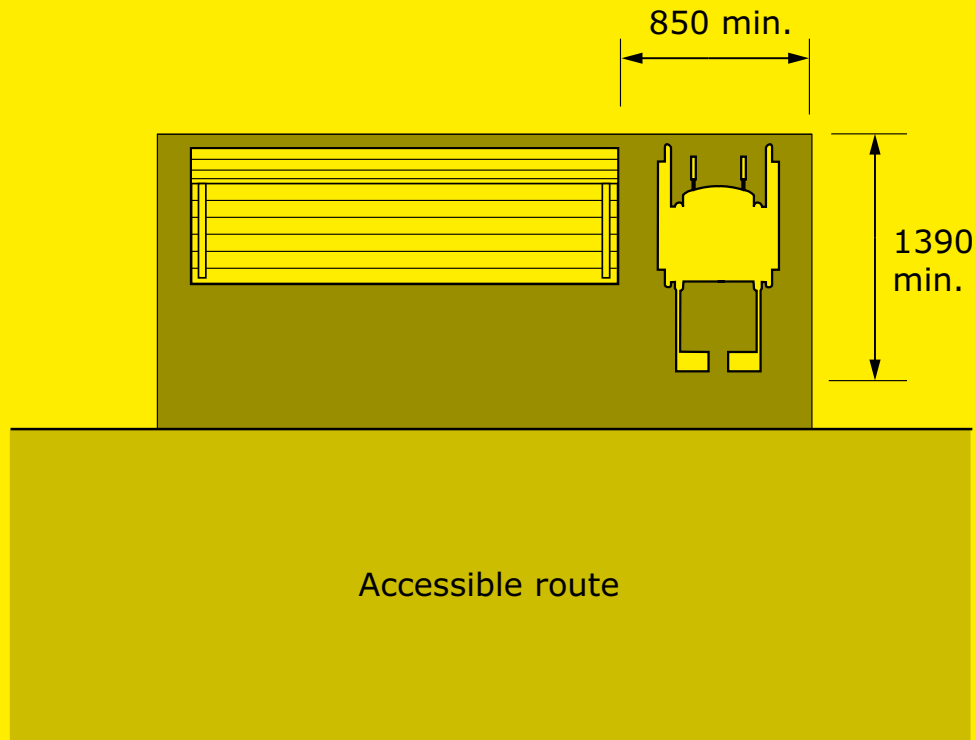

This figure illustrates the dimensions for a level area adjacent to a bench to accommodate a person using a wheeled mobility device, service animal, stroller, walker, etc. The figure shows an unoccupied wheeled mobility device beside a bench in a space that is 850 by 1390 mm. Both the bench and wheeled mobility device are facing an accessible route.

Note: All dimensions are in mm.

6.7.3 Viewing spaces in assembly areas

6.7.3.1 Floor area

A viewing space for a person using a wheeled mobility device shall have a clear floor area that is

a) at least 850 by 1390 mm; and